

## **Technical Specifications for Single Phase Electronic Energy Meter of Class 1.0 Accuracy**

### **1.0 INTRODUCTION**

This document covers technical specification of keypad based pre payment system for single phase consumers. Key pad system must be capable of configuring Slab as well as TOD tariff with complex combination. The system should be compatible with web based vending system (if require in future) where user has to go to specified site with authorized user name and password.

This system required where money should be transferred from a point of sales (POS) to a consumer meter by means of an encrypted numeric printed token secured by Triple Data Encryption System (TDES) which should be transferred to meter through Meter Keypad / Consumer Interface Unit (CIU) keypad / Optical RS232 port / GSM Modem. The prepayment system should be managed centrally by total secure management system with data contained in numeric encrypted codes which are meter specific.

When the consumer buys electricity, he should be given an authorisation by means of an encrypted code. This code issued to him in the form of a paper token which should print on any printer connected to PC or through WEB based services. This code should use to charge meter. This encrypted code should contain relevant information regarding to consumer database, tariff, recharge amount arrear, rebate etc. and stored in the meter memory. This information should display on Meter & CIU display. The Meter & the CIU should have keypad for amount transfer. The meter should design in single box with measuring element, dual latching relay for phase and neutral to escape fraud & disconnect consumer load while credit expire and overloads.

The CIU should be in form of graphical LCD / Led display (minimum 9 digit) which displays multi information with single click in tabular form so that consumer can easily compare the parameters and analyse. The meter & CIU should have bicolour LED for visual indication of credit status and audible alarm for low credit warning and overload, which is configurable at site.

### **2.0 SCOPE**

- a) This specification covers design, engineering, manufacture, testing, inspection & supply of **A.C. Single phase, two wire solid state (static) fully electronic energy meters** of accuracy **class 1.0** keypad prepayment meters with split unit & provision for TOD (Time of Day) tariff. The current rating of Meter is **10-60 A**, with **backlit LCD display** for **240 Volt** systems. The meter should be capable of recording & displaying energy in KWH & demand in KW for single phase two wire A.C. loads respectively for power factor range of **Zero lag – unity – Zero lead**. Meters should have facility/ capability of recording tamper information.

- b)** It is not the intent to specify completely herein all the details of the design and construction of meter. However the meter shall conform in all respects to high standards of engineering, design and workmanship shall be capable of performing commercial operation continuously in a manner acceptable to WBSEDCL, who will interpret the meanings of drawings & specification and shall have the right to reject any work or material which in its judgment is not in accordance therewith. The offered meter shall be complete with all components, accessories necessary for their effective and trouble free operation of the system for the purpose mentioned above. Such components shall be deemed to be within the scope of bidders supply irrespective of whether those are specifically brought out in this specification and / or the commercial order or not.
- c)** Consumer database should be defined with appropriate tariff category & credit / debit limit before commissioning the meter at consumer premises. After that token should be generated to energise the meter. The database & tariff configuration should be prepared by our authorised person. Meter recharging token should be generated by any POS where internet connection available. There should not be any limitations of machine to generate token.
- d)** The original manufacturers of LT A.C. static energy meters shall only quote against this tender. In case of foreign manufacturers their authorized agent may also bid provided that they should be registered vendor and shall have all the testing facilities in India. They should also produce the documents authorizing them as agents, in India.

**It is mandatory that in case of all manufacturers, the offered meter shall be ISI marked and bidder shall have to furnish valid BIS certification along with the offer.**

## 2.0 STANDARDS APPLICABLE

Unless specified elsewhere in this specification, the performance & testing of the meters should conform to the following Indian/International standards, to be read with up to date and latest amendments/revisions thereof as on 90 days prior to floating of tender.

Sl. No.	Standard No.	Title
1	IS 13779, 1999 read with its latest amendments and IS 15884	Specification of AC Static Watt hour meters class 1.0 & 2.0. with Pre-Paid meter.
2	CBIP Report No.88 (revised July 1996) read with latest amendments CBIP – 304 & 325	Specification for AC Static Electrical Energy Meters
3	IS 12346 (1988)	Specification for testing equipment for A.C. Static Electrical Energy Meter (latest amendment).
4	C.E.A. Regulation No. 502 / 70 / CEA / DP&D dt 17/03/2006	Central Electricity Authority (Installation & Operation of Meters) Regulation, 2006.

5	ISO - 27001	Information Security Management System
6	IEC6205 – 31	Prepayment Meter standard
7	IS 14434 (1998)	Polycarbonate Moulding & Extrusion Materials.

### 3.0 CLIMATIC CONDITION

The meters to be supplied against this specification should be suitable for satisfactory continuous operation under the following tropical conditions. Meters should be capable of maintaining required accuracy under hot, tropical and dusty climatic conditions.

- i) Maximum Ambient Air Temperature in shade : 55° C
- ii) Minimum Ambient Air Temperature : (-)10° C.
- iii) Maximum Relative Humidity : 95%(non-condensing)
- iv) Minimum Relative Humidity : 10%
- v) Height above mean sea level : Up to 3000 meters
- vi) Average number of tropical monsoon per annum : 5 months
- vii) Annual Rainfall : 100 mm to 1500 mm

### 4.0 SUPPLY SYSTEM

System	1 Phase 2 Wire
Rated voltage (Vref)	240 V – Phase to Neutral
Rated Current	Basic current 10 Amps (I <sub>b</sub> ), Maximum current 60 Amps (I <sub>max</sub> )
Rated Frequency	50 Hz

### 5.0 POWER FACTOR RANGE

The meter should be suitable for full power factor range from zero (lagging) through to Unity to zero (leading).

### 6.0 POWER SUPPLY VARIATION

The meter should be suitable for working with following supply system variations.

System	1 Phase 2 Wire
Specified range of operation	70% to 120% of reference Voltage i.e. 240 Volt.
Frequency	50Hz ±5%

### 7.0 ACCURACY

7.1 Class of accuracy of the meter should be 1.0. The accuracy should not drift with time.

7.2 Maximum error limit at 1% I<sub>b</sub>, UPF should not exceed +/- 2%.

## **8.0 POWER CONSUMPTION**

**8.1 Voltage Circuit :** The active and apparent power consumption in the voltage circuit including the power supply of meter including split unit at reference voltage, reference temperature and reference frequency should not exceed 2.0 Watt and 8 VA respectively.

**8.2 Current Circuit :** The apparent power taken by current circuit at basic current, reference frequency and reference temperature should not exceed 1 VA.

## **9.0 STARTING CURRENT & RUNNING AT NO LOAD**

The meter should start registering energy at 0.2 % of basic current at unity power factor and first pulse must be appeared within 10 minutes.

Running at no load: When 70% & 120% voltage is applied and no current flows in the current circuit, the test output of the meter should not produce more than one pulse.

## **10.0 MAXIMUM CONTINUOUS CURRENT**

The maximum continuous current in meters should be the current at which the meter purports to meet the accuracy requirement of the specification. The same is indicated in table in clause 4 above.

## **11.0 GENERAL & CONSTRUCTIONAL REQUIREMENTS**

11.1 Meters should be designed and constructed in such a way so as to avoid causing any danger during use and under normal conditions. However, the following should be ensured.

- a) Personal safety against electric shock
- b) Personal safety against effects of excessive temperature. c)  
Protection against spread of fire
- d) Protection against penetration of solid objects, dust & water

11.2 The meter should be designed with ASIC (application specific integrated circuit) and should be manufactured using SMT (Surface Mount Technology) components. Power supply and voltage divider circuits may be of PTH (Pin Through Hole) technology.

11.3 The meter should be housed in a safe, high grade, unbreakable, fire resistant, UV stabilized, virgin Polycarbonate casing of projection mounting type. The meter cover should be transparent or translucent with transparent window for easy reading of displayed parameters, and observation of operation indicators. The meter base may or may not be transparent, but it should not be black in colour. The meter casing should not change in shape, colour, size, and dimensions when subjected to 200 hrs on UV test as per ASTM D 53. It should withstand 650 deg. C. glow wire test and heat deflection test as per ISO 75.

The meter cover should be sealable to the meter base with at least 2 nos. seals.

- 11.4 The meter should be supplied with a transparent extended terminal block cover. The ETBC should not be easily detachable from the base and be secured to the base using a hinging arrangement. ETBC should be closed at the bottom to prevent wires from entering terminal holes, but should have a slot of size 20mm X 20 mm on extreme right hand side of the bottom of the terminal cover as per enclosed Drawing No. terminal block should be made of high grade non-hygroscopic, fire retardant, fire resistant, glass reinforced poly-carbonate with terminal holes of minimum dia 5.5 should be suitable to accommodate the insulation of the conductors, meeting the requirement of IS 13779 / CBIP technical report-88. The minimum center-distance clearance between adjacent terminals should be 13 mm. Terminal cover should have provision for sealing with at least one seal.
- a) **G.E. Plastics**                      **LEXAN 943A or equivalent for cover & Terminal cover / LEXAN 503R or equivalent for base.**
- b)                      **BAYER**                                      **Grade corresponding to above**
- c)                      **DOW Chemicals**                                      - DO -
- d)                      **MITSUBISHI**                                      - DO -
- e)                      **TEJIN**                                      - DO -
- f)                      **DUPONT**                                      - DO -
- 11.5 All insulating material used in the construction of meters should be non-hygroscopic, non-ageing and of tested quality. All parts that are likely to develop corrosion should be effectively protected against corrosion during operating life by providing suitable protective coating.
- 11.6 The meter should conform to the degree of protection IP 51 for protection against ingress of dust, moisture and vermin.
- 11.7 The meter should be capable of providing phase to neutral protection upto 450V for 10 minutes.
- 11.8 The manner of fixing the cables to the terminal block should ensure adequate and durable contact such that there is no risk of loosening or undue heating. Meter should have 2 screws in each terminal for effective clamping of cables. The screws shall not have pointed ends at the end of the thread. Screw connections transmitting contact force and screw fixing which may be loosened and tightened several times during the life of the meter should be such that the risk of corrosion resulting from contact with any other metal part is minimized. Electrical connections should be so designed that contact pressure is not transmitted through insulating material. All terminals and connecting screws and washers should be of tinned / nickel plated brass material.  
**The terminals should be capable of withstanding a current of 150% of I<sub>max</sub> for two hours, continuously.**
- 11.9 The meter should be compact in design. The entire construction should be capable of withstanding stresses likely to occur in actual service and rough handling during transportation. The meter should be convenient to transport and immune to shock and vibration during transportation and handling.

- 11.9 The meter should be compact in design. The entire construction should be capable of withstanding stresses likely to occur in actual service and rough handling during transportation. The meter should be convenient to transport and immune to shock and vibration during transportation and handling.
- 11.10 The meter should have fixing holes, at least one at top and two at bottom. The top hole should be such that the holding screw is not accessible after fixing the meters. The lower fixing screws should be provided under the sealable terminal cover.
- 11.11 The meter should be fitted with **C.T. or SHUNT** for measuring current in the phase element. The Neutral element may have either **C.T. or SHUNT or HALL EFFECT SENSOR** with proper isolation.  
The shunts, used in current circuit must be of high quality having high thermal stability and temperature co-efficient. The shunts should be E-Beam / Spot welded.  
In case of Hall Effect Sensor, meter should record as per requirement of technical specification in normal & tamper conditions and life of battery used for recording & display during single wire operation as per clause 12 (IX) should be guaranteed for 10 years.
- 11.12 The meter cover should be permanently fixed to the meter base by using ultra sonic welding or any other technology which is either equally or more efficacious in such a way that the meter cover can't be opened without breaking the same, i.e. the meter should be break-to-open type. In case any attempt is made to separate the meter cover from the base by using any tools / instruments / device, there should be visible evidence of tampering or attempt to open. The bidder will have to specify the type of technology used by him and will also indicate the tests / standard required for testing the same. However, sealing with commonly available adhesives will not be accepted.
- 11.13 If the top cover is removed, meter should have a permanent indication in its display and it should be remain until reset the tamper through BCS. Permanent display indication also to be provided while any tamper (like current reversal, earth load. Magnetic influence etc.) occur and should remain until reset the tamper through BCS. Here display means display of meter & CIU unit.
- 11.14 Sealing Arrangement: The sealing screws used for the meter cover shall be fixed upside down so that these are tightened from the rear. The sealing screws shall be Tinned Brass or Nickel plated steel. In absence of sealing screws provision of holes on meter body should be kept for sealing purpose.  
The sealing screws provided for meter terminal cover should be Tinned Brass or Nickel platted steel.

## 12.0 LOAD SURVEY

Sixty days (60) Load Survey with 30 Min. integration Period is required. Survey Parameters are KWh, Voltage and Current.

## 12.1 ANTI-TAMPER FEATURES

The meter should have the following anti-tamper features and should record & register forward energy accurately under the following conditions :

- i) Input phase and neutral connections are reversed. Current reversal may be provided in display circuit (optional)
- ii) Incoming mains is connected to outgoing terminals and load is connected to incoming terminals.
- iii) A combination of conditions (i) and (ii) occurs.
- iv) Load return is connected to a local earth and not returned to the meter as well as the phase and neutral at supply side are reversed.
- v) A part of the load is returned to a local earth and the other part is returned to the meter. Average of three nos reading will be considered.
- vi) Meter should record energy with maximum error of  $\pm 4\%$  even in absence of neutral wire not connected at incoming & outgoing, i.e. single wire operation. In such condition Meter should start recording energy at 1.0 Amps. However, meters, which are immune or maintain better accuracy, will be preferred. If the consumer will not be able to draw the power from meter in single wire mode then this clause will be invalid.  
**Note:** Test will be carried out in two or three loads ranging from 1.0A to 30A
- vii) The meter should be immune to Electro Static Discharge or sparks of 35 KV. approx, induced by using frequency-generating devices having very high output voltage. Tests in this respect will be conducted by using commonly available devices and during spark discharge test, spark will be applied directly at all vulnerable points of the meter for a period of 20 to 30 min and meter should record under this condition. After application of spark discharge meter should record correctly within the specified limits of errors. Beyond 35 KV meter should record as tamper if not immune (optional).

The Meter should also be immune for tamper by application of radiated spark through Jammer Circuit.

- viii) Meter should record energy with maximum error of  $\pm 4\%$  on Injection of DC (+) ve & DC (-) ve in neutral, injection of discontinuous DC (7-10 Hz) in neutral, injection of chopped AC in neutral. During D.C or chopped A.C injection in neutral meter should register at  $V_{ref}$ . However, meters, which are immune or maintain better accuracy, will be preferred. Maximum chopping for AC injection will be 25% to 30% at peak end. Tests in this respect will be conducted by using a device available with us for chopped AC injection (60V to 300V) & steady / pulsating DC injection

**Note:**

- a) D.C. injection test will be carried out in three different loads ranging from 5A to 30A and chopped A.C. injection test will be carried out in five positions of regulators in three different loads ranging from 1A to 30A.
- b) In case of recording of energy at  $I_{max}$  during D.C or chopped A.C injection in neutral, tamper events should be logged as DC injection or AC injection.
- c) If the meter is immune / records energy within error limit of  $\pm 4\%$  during D.C or chopped A.C injection in neutral or any other neutral disturbance, tamper events should be logged as Neutral Disturbance.

Meters should offer compliance to requirements of CBIP-88 and its amendments for tampering using external magnets. The meters should be immune to 0.2T of A.C.& D.C. magnetic fields and 0.5 T permanent magnetic fields or goes to  $I_{max}$  with proper stamping / indication at tamper events.

The meter should offer a link less design i.e. there is no isolation link provided between the current and voltage circuits and hence there would not be any possibility of tampering with the same. The meter should be capable of recording the following tamper events in memory (minimum 100 events) with date and time stamp preferably along with snapshots of V, I, PF and KWh. The logging will be on FIFO basis.

- ➡ Current reversal
- ➡ Neutral Disturbance
- ➡ Earth Tamper
- ➡ Magnetic Tamper

The duration of tamper before it is logged should be a user programmable through authenticated commands. But it should not be more than 5 min. Tamper logic will be checked during testing. Thresh hold Value along with Tamper logic will be given at the time of Pre-bid meeting.

## 13.0 DISPLAY

13.1 The measured value(s) should be displayed on a Liquid Crystal display (LCD) register. The height X width of the digit should be minimum 8.0 X 5 mm. The KWh energy registration should take place with at least 6 complete digits. The display should have backlit capability for easy reading. When the LCD is placed at a constant temperature of 65 deg C for a period of 30 minutes in operating condition and 80 deg C for 30 minutes under de-energized / storage condition, it should not get deformed.

The LCD should be of TN (Twisted Pneumatic) type with display size area of at least 40 X 15 mm. The display should have wide viewing angle of at least 70 deg. Dot Matrix type LCD will not be acceptable.

Display should have viewing angle 35 degree up & down from eye level. Backlit also to be provided in Graphical CIU.

13.2 The data should be stored in non-volatile memory (NVM). The non-volatile memory should retain data for a period of not less than 10 years under un-powered condition. Battery back-up memory will not be considered as NVM.



13.3 The register should be able to record and display starting from zero, for a minimum of 1700 hours, the energy corresponding to rated maximum current at reference voltage and unity power factor. The register should not roll over in between this duration.

13.4 In addition to provide serial number of the meter on the display plate, the meter serial number should also be programmed into meter memory for identification through communication port for CMRI / Laptop / meter reading print out.

13.5 There should be two modes of information display, these are Normal Display & Engineering Display.

#### **14.0 DISPLAY SEQUENCE**

The meter should display the required parameters in two different modes as follows

##### **14.1 Normal Display Mode:**

The meter should provide following information on the display and the same shall also be available on the split / display unit.

1. LCD Test
2. Real Time
3. Date
4. Cumulative Active energy (forwarded) reading (kWh)
5. Credit balance in INR
6. The days left based on the last seven days average consumption
7. Consumption history of last month.
8. Present load cost in Rs/ Kwh
9. Maximum demand along with date & time for current & last months
10. Instantaneous current (both Phase & Neutral), voltage, p.f., KW etc.
11. Tamper count.
12. Meter serial No.

Any other useful display gladly acceptable.

Each parameter should be on meter display for AT LEAST 5 seconds and the time gap between two Normal-cycles should be have some specific times

The meter should also be capable of offering a resolution of 4 digits after decimal & 2 digit before decimal for the high resolution KWh display and 2 digits after decimal & 4 digits before decimal for the high resolution Wh display. Any other useful display will be acceptable.

Permanent display with Normal mode should be provided like;

- Supply indication
- Relay status current slab number
- Current reverse indication (if condition occurred)
- Earth load indication (if condition occurred)
- Magnet influence (if condition occurred)

## 14.2 Engineering Display Mode

This display shall be available only upon the application of valid codes on the meter, and shall enable the display of the following:

- Software version
- All the limiting parameters value, such as load limit, current limit & emergency credit limit.
- Switch operation counts

## 14.3 Display unit:

- The Meter shall be supplied with a separate display unit
- The display unit shall be powered up from the meter
- The display unit shall have a LCD display similar to that of the meter
- The display unit shall have a key pad to enter the code. The keypad should be similar to the keypad available on the meter
- The display unit shall have a RJ11 connection port to connect to the meter
- Maximum distance between the display unit and the prepayment meter shall be 100 meters.
- The display unit & energy meter shall be connected using a 4 wire connection cable (similar to telephone cable)
- The display unit shall have a buzzer to generate alarm signal in case of low credit and overload.

### 14.3.1 Key pad

- a) The Keypad buttons should have numbers, which should clearly visible and resistant to wear. The layout of the numbering should be same as that used on standard telephones for numbers 1 to 9 and buttons as '#', '\*' and '0'. Button 6 or 7 has physical identification of raised printing to aid consumer having poor sight.
- b) The codes encryptions and decryption should be carried out by triple DES using an internationally recognized standard.
- c) The meter should permit a time delay upto 15 seconds between two key strokes while entering token for recharging. Error message should be display if delay time is more than 15 seconds.
- d) "Account balance" should be display regularly on CIU with current date and time to avoid sleep mode.

#### 14.4 Key pad Display

The meter key pad display buttons should display following parameters;

Key "1" – Based on the previous week's consumption, the meter calculates the approximate number of days left before the credit ends.

Key"2" – Display the consumption data of the last day, last week, current month & the last month in INR.

Key"3" – Display price applicable for each slab and slab rate-wise energy consumption.

Key"4" – Display latest five vendors code which entered into meter to credit it.

Key"5" – Display cumulative credit amount, cumulative fixed charge, daily fixed charge, Meter serial number & sanctioned load.

Key"6" – Display instant load in KW, Voltage, Current (both Phase & Neutral), p.f.

Key"7" – Display standing charges & minimum charges.

Key"8" – Display current month MD & last month MD with date & time.

Key"9" , & Key"" are left for manufacturer's choice of operation.

Key"0" – Display Date, Time & emergency credit limit value in INR / Refund code.

Key"#" – Display 'Authenticated Billing Code'

The meter should display the atleast 20 digit authenticated meter reading code on key #.

Key position can be interchanged subject to approval of appropriate authority.

The full 20 digit token shall contain the following frozen value at midnight (00:00 Hr) of month end

- 5 digit cumulative KWh energy register
- Date of frozen data
- Credit balance, it may positive or negative
- The tamper flag, which only indicates whether there is any tamper or not.

#### 15.0 MAXIMUM DEMAND REGISTRATION & RESET

Meter should continuously monitor & calculate the average maximum demand for each demand interval time of 30 minutes (sequential) and maximum of these in a calendar month should be stored along with date and time when it occurred. The maximum demand should automatically reset at 24:00 hrs. of the last date of each calendar month.

The integration period should be set as 30 minutes, on real-time basis.

The active forwarded energy, maximum demand in kW should be recorded & available along with Load Factor & Average Power Factor for a minimum period of last 6 months in BCS..

#### 15.1 DATA STORAGE

The meter should be capable of storing the following parameters in NVM

- ⇒ Billing parameters like Active KWh, MD in KW, L.F. Average p.f. for last 6 months
- ⇒ Consumption details of previous 6 months in term of Rupees.
- ⇒ Cumulative Active Energy
- ⇒ Time of use of energy & MD
- ⇒ Tamper atleast 50 events on FIFO basis

These parameters should be downloaded through CMRI and remotely through GSM modem compatible with BCS.

## **16.0 TIME OF USE / Time of Day MONITORING**

The meter should offer the capability of time of use monitoring for energy. Minimum 4 registers should be capable of being configured for TOD monitoring for Peak / off peak hours. Time slots will be supplied before execution of supply the meter. Hrs. In case of any change of Time slots in future as per directive of SERC, the same is to be incorporated by the supplier even after completion of the order as per instruction from the appropriate authority. From the above it is clear that TOD timings is programmable and it should be possible to change the time slot / period for TOD recordings through the HHU unit or through vending station.

During sample meter submission any default timings set by the manufacturer is acceptable but at the time of execution of supply of meter TOD timings must be set as per specification.

## **17.0 SELF- DIAGNOSTIC FEATURE**

The meter should be capable of performing complete self diagnostic check to monitor integrity of data memory location at all time. The meter should have indication for unsatisfactory / nonfunctioning / malfunctioning of the following :

- a) Time and date on meter display
- b) All display segments on meter display
- c) Real Time Clock (RTC) status in meter reading prints out at BCS end
- d) Non-volatile Memory (NVM) status in meter reading prints out at BCS end
- e) Tamper status if any tamper condition occurred.

## **18.0 COMMUNICATION PORT**

The meter should have a galvanically isolated optical communication port for data communication with CMRI / Laptop. The port should be compatible with IEC 1107/ PACT / ANSI. Adequate sealing provision should be provided.

## **19.0 CMRI / Laptop / BCS REQUIREMENTS**

The Common Meter Reading Instrument (CMRI / Laptop) should be capable of being loaded with user-friendly software (MS-DOS 5.0 or higher version compatible) for reading / downloading meter data. Windows based Base Computer Software (BCS) should be provided for receiving data from CMRI / Laptop and downloading instructions from base computer software to CMRI / Laptop.

The BCS should be WINDOWS 7 or above, pro based and copyrighted.

The data stored in the meters memory including defrauded energy should be available on the BCS

The vendor should also supply the necessary CMRI / Laptop software.

The bidder has to supply the Meter Reading protocol (API). free of cost. The protocol should not be complicated & should be easily understandable to introduce compatibility between meters, BCS and CMRI of other makes. The bidder shall indicate the relevant standard to which the protocol complies. The compatibility of transferring data from the meter to CMRI & then to the BCS should be easily established. Any change or up gradation of CMRI software or BCS in future, required for any reason, has to be done by the supplier at his own cost. It should not be possible to alter date in the meter by-passing commands from the CMRI / Laptop or through vending station.. For alteration of RTC time, change of TOD timing, Billing parameters, etc it should be possible to perform this functions through CMRI but only through authenticated commands sets by BCS after scheduling for particular meter sl. nos. No alternation, change should be possible through authenticated commands sets by BCS without scheduling of meters. Moreover, no alternation, change should be possible using CMRI only, i.e. the control has to be with the BCS or through vending station.

One CMRI /Laptop (Specification will be fixed on Pre Tender Meeting) with every 400 nos Meter with 100 Nos Meter to PC USB type cord should be supplied to the office of the C.E. (DTD) for distributions at sites.

**It should be possible to read the meter using CMRI /Laptop during power-off condition though no indication in CIU.**

## 20.0 MARKING OF THE METER

The marking on the meter should be in accordance with relevant clauses of IS13779.

The basic marking on the meter nameplate should be as follows (all other markings as per IS should also be there) :

- a) Manufacturer's name & trade mark
- b) Type Designation
- c) No. of phases & wires
- d) Serial number (Size not less than 5mm)
- e) Year of Manufacture
- f) Reference Voltage
- g) Rated Current
- h) Operating Frequency
- i) Principal unit(s) of measurement
- j) Operating Frequency
- k) Principal unit(s) of measurement
- l) Manufacturer's name & trade mark
- m) Type Designation
- n) No. of phases & wires
- o) Serial number (Size not less than 5mm)
- p) Year of manufacture
- q) Reference Voltage
- r) Rated Current
- s) Operating Frequency
- t) Principal unit(s) of measurement
- u) Meter Constant (imp/kwh)
- v) Class index of meter
- w) "Property of WBSEDCL"
- x) Purchase Order No. & Date
- y) Guarantee (Guaranteed for a period of 5 1/2 Yrs. from the date of delivery)
- z) BIS marking
- aa) Place of manufacture

## **21.0 CONNECTION DIAGRAM & TERMINAL MARKINGS**

The connection diagram of the meter should be clearly shown on terminal cover.

## **22.0 OUTPUT DEVICE**

The meter should have a test output accessible from the front and capable of being monitored with suitable testing equipment while in operation at site. The test output device should be provided in the form of LED output. There should be adequate clearance of the test output from other outputs (LED / LCD for earth, for reverse, for power on etc) so that there is no interference of other outputs while performing accuracy test with standard scanners.

The relation between test output and the indication on display should comply with the marking on the name plate (imp per KWh)

## **23.0 ELECTRO-MAGNETIC-COMPATIBILITY & INTERFERENCE REQUIREMENT**

The meter should meet EMI / EMC requirements as specified in the relevant standards described in Clause 2.0 of this specification.

## **24.0 VENDING STATION & CIU**

The Vending system should be “web based Vending System” for easy token generation by any POS. There should not be any limitation of vending machine. In case of client server / two tier architecture, the Meter manufacturer should hold the responsibility of entire gamete of communication and other technology to established ‘web based vending system’ as mentioned.

Customer Interface unit should have high resolution graphic display which should be user friendly and provides a host of information to the consumers in tabular format with single key.

## **25.0 PRE PAID FEATURES**

**Token and Credit Amount:** The online single token could be generated up to 9.99999 Lakhs (6 digit single vend token) INR and the same debit limit should be provided into the meter.

### **Tariff Structure:**

- a) The Tariff should support both instant and delayed tariff publication and activation for Slab & TOD tariff.
- b) The tariff made in offered software will active on the same day at 00:00 hours & will update in the meter as soon as token punched into the meter.
- c) The delayed tariff will activate on every first of the calendar month since the calculation of the fixed charges is made based upon 365 days & money get deducted based upon the Kwh consume in a month. Hence the delayed tariff get activated on every first day of the calendar month.

- d) Meter should be capable for both Slab and Time of day (TOD) tariff.
  - e) Slab and TOD boundaries should be defined instantly (Today itself) in desired range.
  - f) Meter should support maximum of 8 slab boundaries with maximum of 8 rate registers for slab tariff.
  - g) Meter should support maximum of 8 rate registers with maximum of 8 non overlapping time zones in a day.
  - h) Consumer type, Category type should be mentioned in desired alphanumeric character.
  - i) There will be separate tariff category for the single & three phase consumers. j) Using the on line vending system, it shall be possible to define the minimum charge for the applicable tariff category. If the consumer consumes electricity equivalent of amount less than the minimum charge then at the end of the billing period the meter shall deduct the difference of the minimum amount & the monthly consumption (amount).
  - k) Fixed charges should be sum of meter rent and any other fixed amount for whole month and it should deduct by the meter on daily basis to avoid an abrupt fall in credit and consumer inconvenience.
  - l) Energy duties(Tax) facility should be provided on basis unit rates of consumption in percentage and the same be integrated in rates shown on display.
  - m) Rebate should be provided to give reduction to consumer according to proper token transaction.
  - n) The meter should be configured for KWh billing through token only.
  - o) The amount should be deducted after completion of one KWh to avoid fractional error in paisa.
- This manual fine calculation grows consumer satisfaction an amount deduction and tariff configuration.

## 26.0 SALIENT FEATURES:

The salient features of the meter should be as given below;

- a) A key pad should be provided on meter front cover for token punching to energise meter and view display details of various parameters provided on respective key.
- b) Graphical consumer interface unit (CIU) should be provided to access meter from consumer premises. CIU should have telephonic style keypad to energise meter and see display details provided on respective key.
- c) The meter should have legible LCD with starburst display for displaying alphanumeric characters and information like Total credit amount, credit balance, cumulative KWh. Slab details and their rates, current MD with occurrence date & time.
- d) The meter should be tested, calibrated and sealed at production plant before dispatch. Further no modification of calibration is possible at site by any means what so ever.
- e) The meter should display message on accepting on accepting valid token transaction and on rejecting invalid token transaction with an additional sound.



- f) The meter should be capable to accept numeric token via keypad or through GSM modem and credit the purchased amount to the meter. This credit should be added to the existing balance available in the meter and the same amount should also be added to cumulative amount credited to meter.
- g) The system should have facility to save new generated token in "XML Document" after its generation and the same document could be used to debit the amount & configuration into the meter through GSM modem for remote communication.
- h) The credit should be debited by the meter based on the electricity consumption according to the rate including the fixed charges, minimum charges etc. as defined in tariff configuration.
- i) The fixed charge should be deducted from the meter, if power is not available then the amount will be deducted when the power is restored. There should be need of token transaction to stop fixed charge while meter removed from the site and keep to store.
- j) A visible low credit warning should be provided with bi-colour LED indication (prefer Green while for healthy zone else Red colour) when the credit fails below defined alarm limit or it must be available on meter default display cycle and the buzzer alarm should be available.
- k) An audible low credit warning should be provided to sound after every half an hour duration for 30 second till the alarm is acknowledged by consumer by pressing either meter or CIU unit.
- l) When the credit goes to zero, the meter should disconnect the output supply & should reconnect only if emergency credit limit is provided to consumer or meter charged with a new token which has additional amounts then zero.
- m) The meter should be capable to configure for emergency credit limit so that some defined amount could be provided to consumer after zero balance. After this defined amount meter should disconnect the output supply and restore only when meter balance reaches the amount additional to zero.
- n) The meter should have facility of load limit configuration by which if it exceeds result in disconnection of consumer output supply.
- o) Friendly credit facility must be inserted in the meter memory. The meter should not disconnect consumer's supply even if their credit fails down to emergency credit limit during night hours on weekly – off (Sunday) or pre-defined public holiday. It must be factory programmed only. The meter should disconnect supply after end of such friendly hours and days. When meter recharges with new credit it should adjust the debited amount first and then normal operation goes on.
- p) Relay should be provided in both phase & neutral element in the meter to let alone fraud and single wire tamper. It should be bi-stable type latching switch designed as per international standard.

## **27.0 FUNCTIONAL PARAMETERS**

- a) Consumer database, Tariff, sanctioned load, debit credit limit etc. should transfer to meter memory by the initial token transaction. Any modification in consumer profile should be updated through subsequent vending transactions.

- b) Fixed charge should be deducted on daily basis & irrespective of the consumption. It should be deducted even after disconnection of supply and stored as negative value (credit amount) which should be adjusted in the next vending transaction.
- c) Consumption charge should be deducted as per the current tariff structure. d) Emergency credit limit should be tariff category wise.
- e) Vending codes should be meter specific & could not be used by another meters. This code can be reused if lost but the same token can't be reused.
- f) Message facility should be provided for individual consumer or for all consumers linked with the system. The activation and expiry date of the message should be defined as desired. The message should intimate to consumer till valid date range.
- g) Meter configuration as well as consumer database details should be uploaded into system with a single click.
- h) If meter got fault and sent for service, tracing system should be available with mode of conveyance & dispatch date with proper documentation. The separate report could be generated if required to analyse.

## **28.0 PROCUREMENT OF SEALS :**

The manufacturer of meter will be responsible for sealing of the meters at his works with his own Polycarbonate / paper seals with manufacturer logo / name of manufacturer and sequential numbers or irreplaceable seals laser marked with sequential numbers.

A Tracking & recording software (25 nos. or more as per our requirement) for all new seals shall be provided by the manufacturer of the meter so as to track total movements of the seals starting from manufacturing, procurement, storage, record keeping, installation, series of inspections, removal & disposal.

Seal tracking software should be submitted and installed at PC / Laptop of the purchaser before commencement of supply of meters i.e. it must be supplied before / at the time of offering first lot inspection.

### **1. GUARANTEED TECHNICAL PARTICULARS :**

The bidder shall furnish all the necessary information as desired in the Schedule of Guaranteed Technical Particulars and data, appended with this Specification. If the bidder desire to furnish any other information(s) in addition to the details as asked for, the same may be furnished against the last item of this Annexure-I

### **2. TECHNICAL DEVIATIONS :**

Any deviation in Technical Specification as specified in the Specification shall be specifically and clearly indicated in the Schedule of deviation format.

### 3. TESTS :

#### i) Type Testing of Meter :

The offered meters should be type tested at any NABL accredited laboratory in accordance with IS 13779 with latest amendments, CBIP Report 1988 with latest amendments. The type test report should not be more than 2 (Two) years old. A copy of the Type Test results should be enclosed with the offer. If there is any modification in the design/parameters of the specifications or use of constituent materials in the offered meters submitted with the offer, from the meter which was submitted type tested, which may affect the characteristics as well as parameters of the meter, revised type test certificates as per the design, parameters and constituent material used in the offered meter, shall have to be submitted failing which the offer may be liable to be rejected.

**Type Test Certificate from any NABL accredited Lab. shall only be considered.**

Type test certificate should contain the following information clearly :

- 1) Type of display i.e. whether counter is mechanical type or LCD.
- 2) Class of accuracy.
- 3) Meter constant

#### ii) Acceptance tests :

A. The acceptance tests as stipulated in CBIP / IS (with latest amendments) and shall be carried out by the supplier in presence of purchaser's representative. Lot size, sampling and procedure to be followed for acceptance test will be as stated below

The lot size of Meters is 1001 nos. & no. of Sample Meters to be selected at random from the lot is 32 nos.

The following tests shall be carried out on all the 32 nos. meters thus selected at random.

- The WBSEDCL's/NTESCL's Engineers shall witness the various quality control measures adopted for verification of different components of meters and satisfy themselves about the same. They shall also inspect the protocol for maintaining the accuracy of the meter testing equipment with reference to the standard at manufacturer's meters testing station. • Physical examination of the meters.
- Non-registration with Voltage along at 70% V ref and at 120% V ref.
- Starting current at 0.2% I basic Upf
- High voltage test.
- Insulation resistance test.
- Test of protection for withstanding 450 volt between phase & neutral for 10 minutes.
- Test of endurance up to 150% I max

During the above tests, if no. of meter fails is less than or equal to 1 No., the lot shall be considered to be conforming to the above tests. If no. of meter fails is greater than 1 No. but less than 4 nos., further re-sampling will be done and the nos. of re-sampled meters shall be 32 nos. selected at random from the Lot of 10,000 nos.

The re-sampled meter will be subjected to the tests as mentioned above and if nos. of meters fail in two samples combined (64 nos.) is less than 4 nos. the lot shall be considered to be conforming to the above tests otherwise rejected.

Further testing for 8 nos. meters selected from 32 nos. sample meters will be carried as follows :

- Limits of error on all the sample meters at :

1% I basic	1.0 pf.
2% I basic	1.0 pf.
5% I basic	1.0 pf., 0.5 pf. Lag & 0.8 lead
10% I basic	1.0 pf., 0.5 pf. Lag & 0.8 lead
50% I basic	1.0 pf., 0.5 pf. Lag & 0.8 lead
100% I basic	1.0 pf., 0.5 pf. Lag & 0.8 lead
200% I basic	1.0 pf., 0.5 pf. Lag
600% I basic	1.0 pf., 0.5 pf. Lag
- Test of meter constant and meter dial for one unit at 200% I basic, 0.866 pf. Lag.
- Power loss on voltage & current circuit.

Further testing for 3 Nos. sample meters will be carried as follows:

- Repeatability of error test at 5% I basic Upf & 100% I basic Upf.  
The maximum divergent should be less than 0.1.

If anyone of the meter fails on any of the above tests, the lot will be rejected.

Further testing for 1 No. sample meter will be carried as follows:

- Magnetic induction of external origin (AC & DC).
- Electro Static Spark Discharge of 35KV
- Tamper & Fraud protection as per Clause 12 ( I to vii) (Anti-tamper feature) of our specification.
  
- Injection of DC pulse (low frequency) in the neutral.
- Dry –heat test as per clause 12.6.1 of IS:13779/99.

At least one sample selected from any lot of the meters offered for inspection will be sealed by us and handed over to the supplier for testing at NABL accredited laboratory. Presence of purchaser's representative during dry heat test at NABL accredited laboratory is not required. But in the test report meter SI. No. & meter body seal nos. is to be mentioned.

- Shunt test by applying 100 Amps continuous load for minimum two hours for verification and conformation for quality of shunt & its E-beam welding.
- Physical verification of internal components.

If the meter fails on any of the above test, the lot will be rejected. Facilities/arrangement for conducting ageing test should be available with manufacturer

**iii) Retesting after delivery**

NTESC / WBSEDCL will carry out re-testing of the supplied meters at their laboratory. Re-testing of the supplied meters will be conducted on sample meters collected from different stores of the consignees as per the procedure followed for acceptance test (except dry heat test & shunt test) during inspection & testing of the supplied meters at manufacturer's works. Re-testing of the supplied meters will be completed within one month from the date of receipt of meters at different stores. Date of re-testing of meters will be intimated to the supplier for witnessing testing of the meters.

In case the meters are not in order as per our observation during inspection and testing of the supplied meters, the lot will be declared defective and in that event meters supplied are to be replaced by the manufacturers free of cost including free transportation from the site to their works and back. The replaced meters are to be offered for inspection & testing and Acceptance test of will have to be carried out by the supplier in presence of purchaser's representative.

**iv) Routine Tests :**

Each and every meter of the offered lot shall undergo the routine tests as well as functional tests as per IS: 13779/1999, CBIP Report latest 304 and 325 and after sealing of the meters, the manufacturers will submit the routine test report of all the meters as well as a statement showing seal SI. Nos. against each meter, SI. No. of offered lot in soft copy (MS WORD or EXCEL format), to the General Manager (Com) NTESC Ltd and a copy to Chief Engineer, DTD, along with offer letter for acceptance test.

Technical Specification of Single Phase Pre-paid Static Energy Meter

**v) TEST FACILITIES :**

The tests for equipment / instrument shall be carried out as per relevant Standards and test certificates shall be furnished for scrutiny. The Bidder shall indicate the details of the equipment available with him for carrying out the various tests as per relevant Standards. The bidder shall indicate the sources of all equipments/instruments.

**NOTE :** The standard meters used for conducting tests shall be calibrated periodically at any NABL Accredited Test Laboratories and test certificates shall be available at Works for verification by purchasers representative.

The manufacturer shall have at least the following testing facilities to ensure accurate calibration :

- AC high voltage test
- Insulation test
- Test of no load condition
- Test of Starting condition
- Test on Limits of error
- Power loss in voltage and current circuit
- Test of Repeatability of error
- Test of meter constant
- Test of magnetic influence

#### **4. INSPECTION :**

The purchaser may carry out the inspection at any stage of manufacture. The manufacturer shall grant free access to the purchaser's representative at a reasonable time when the work is in progress. Inspection and acceptance of any equipment under this specification by the purchaser shall not relieve the supplier of his obligation of furnishing the equipment in accordance with the specification and shall not prevent subsequent rejection if the equipment is found to be defective.

The Supplier / Manufacturer will have to arrange for to & fro Airfare for at least two Engineers of WBSEDCL/NTESC Ltd including boarding, lodging and local conveyance for witnessing acceptance tests.

All acceptance tests and inspection shall be made at the place of manufacturer unless otherwise especially agreed upon by the Bidder and purchaser at the time of purchase. The Bidder shall provide all reasonable facilities without charge to the inspector, to satisfy him that the equipment is being furnished in accordance with this specification.

The supplier shall keep the purchaser informed in advance, about the manufacturing programme for each lot so that arrangement can be made for inspection.

The purchaser reserves the right to insist for witnessing the acceptance / routine testing of the bought out items. The supplier shall give 15 days for local supply / 30 days in case of foreign supply advance intimation to enable the purchaser to depute his representative for witnessing the acceptance and routine tests.

The purchaser reserves the right for type testing of any meter & meter casing etc. from any of the offered lots, received at any destination stores.

#### **5. SUBMISSION OF SAMPLE METER**

Tender paper and Sample Meter will be submitted to the General Manager. (Com), NTESC Ltd. at its Administrative Building at Finance Centre, New Town, Rajarhat from 11.00 A.M. to 04.00 P.M. on week days & from 11.00 A.M. to 01.00 P.M. on Saturday within the specified period of submission of the tender document for which he will be given a receipt by the Office of the NTESC Ltd.

The bidder will be given a receipt, jointly signed by the bidder and NTEESC officials, mentioning the samples and papers submitted by the bidder as per check list.

- a) While submitting the samples and required documents as per Annexure-IV, the bidder has to submit two numbers of sealed meters as per the specifications stated herein before, without the welding of the meter base and cover and body screw caps and BCS (as per specification).
- b) They should also submit one prototype of meter base and cover (with body screw caps) properly welded.
- c) The date of testing of sample meters will be intimated to the bidders by C.E.(DTD) after consulting with NTEESC officials and on the date of testing of sample meters of a particular bidder, he shall come prepared with the following :
  - BCS (as per specification)
  - CMRI compatible with BCS and loaded with CMRI software and laptop compatible with BCS.
  - Any other accessories required for observing the performance and capabilities of the meters.
  - Operating/threshold value at which the meter will record energy as per specified limits of errors and also logic at which meter log tamper at different tamper conditions.

Sample meter testing will be conducted as per the enclosed format (Annexure-V). During such testing, other bidders will also be allowed to witness the testing and only one representative of each bidder with proper authorization letter from his organization will be allowed to witness sample testing of a particular bidder.

If any bidder send his representative to witness sample testing of other bidders, his representative will have to be present till completion of sample testing of a particular bidder and test reports are to be signed by his representative.

## **6. QUALITY ASSURANCE PLAN :**

The design life of the meter shall be minimum 20 years and to prove the design life the firm shall have at least the following quality Assurance Plan: -

- The factory shall be completely dust proof.
- The testing rooms shall be temp. and humidity controlled as per relevant standards.
- The testing and calibrating equipments should be automatic and all test equipment shall have their valid calibration certificates.

Technical Specification of Single Phase Pre-paid Static Energy Meter

- Power supplies used in testing equipment shall be distortion free with sinusoidal wave- forms and maintaining constant voltage, current and frequency as per the relevant standards.

During the manufacturing of the meters the following checks shall be carried out

- i) Meter frame dimensions tolerances shall be minimum.
- ii) The assembly of parts shall be done with the help of jigs and fixtures so that human errors are eliminated.

The meters shall be batch tested on automatic, computerized test bench and the results shall be printed directly without any human errors. The Bidder shall invariably furnish the following information along with his bid, failing which his bid shall be liable for rejection. Information shall be separately given for individual type of material offered.

- Statement giving list of important raw materials, names of sub-suppliers for the raw materials, list of standards according to which the raw materials are tested, list of tests normally carried out on raw materials.
- Information and copies of test certificates in respect of bought out accessories.
- List of manufacturing facilities available.
- Level of automation achieved and lists of areas where manual processing exists.
- List of areas in manufacturing process, where stage inspections are normally carried out of quality control and details of such tests and inspections.
- List of testing equipment available with the bidder for final testing of equipment specified and test-plant limitations, if any, vis-à-vis type, special acceptance and routine tests specified in the relevant standards and this specification. These limitations shall be very clearly brought out in schedule of deviations.

The manufacturer laboratory must be well equipped for testing of the meters. They must have computerized standard power source and standard equipment calibrated not later than a year (or as per standard practice). The details of testing facilities available for conducting

- a) The routine tests.
- b) Acceptance tests shall be furnished with the bid.

## **7. MANUFACTURING ACTIVITIES**

All the materials, electronics and power components, ICs used in the manufacture of the meter shall be of highest quality and reputed make to ensure higher reliability, longer life and sustained accuracy.

The manufacturer should use Application Specific Integrated Circuit (ASIC) or Micro controller for metering functions.

The electronic components shall be mounted on the printed circuit board using latest Surface Mounted Technology (SMT) except power components by deploying automatic SMT pick and place machine and re flow solder process. The electronic components used in the meter shall be of high quality and there shall be no drift in the



accuracy of the meter at least up to 10 years. Further, the Bidder should own or have assured access (through hire, lease or sub-contract) of the mentioned facilities. The PCB material should be of glass epoxy FR-4 grade conforming to relevant standards.

All insulating materials used in the construction of meters shall be non-hygroscopic, non-aging and of tested quality. All parts that likely to develop corrosion shall be effectively protected against corrosion by providing suitable protective coating.

Quality should be ensured at the following stages:

At PCB manufacturing stage, each board shall be subjected to bare board testing. At insertion stage, all components should undergo testing for conforming to design parameters and orientation.

Complete assembled and soldered PCB should undergo functional testing using test equipments (testing jig).

**Prior to final testing and calibration, all meters shall be subjected to accelerated ageing test to eliminate infant mortality, i.e, meters are to be kept in ovens for 72 hours at 55 deg. Centigrade temperature & atmospheric humid condition. After 72 hours meters should work correctly. Facilities / arrangement for conducting ageing test should be available with the manufacturer.**

The calibration of meters shall be done in-house.

The bidder should submit the list of components used in the meter along with the offer.

A detailed list of bought-out items, which are used in the manufacture of the meter, should be furnished indicating the name of firms from whom these items are procured. The bidder shall also give the details of quality assurance procedures followed by him in respect of the bought-out items.

The details of testing facilities available for conducting the routine and acceptance tests and other special tests on the meter shall be furnished with the bid. The facility available if any for conducting type test may also be furnished.

## **8. DOCUMENTATION :**

Seventy-five sets of operating manuals shall be supplied to the office of the NTESC Ltd / CE (DTD) for distribution at sites.

**One set of routine test certificates shall accompany each dispatch consignment.**

The acceptance test certificates in case pre-dispatch inspection or a routine test certificate in cases where inspection is waived has to be approved by the purchaser.

## 9. GUARANTEE:

The meters should be guaranteed against any manufacturing defects arising out of faulty design or bad workmanship or component failure for a period of **5 ½ years** from the date of supply.

Life of battery used for the meter should be guaranteed for **10 years**.

The meter/battery found defective within the above guarantee period shall be replaced by the supplier free of cost within 60 days of the receipt of intimation of failure / defect.

### **REPLACEMENT OF DEFECTIVE METERS :**

The meters declared defective by the WBSEDCL/NTESCL shall be replaced by the supplier up to the full satisfaction of the WBSEDCL at the cost of supplier. Failure to do so within the time limit prescribed shall lead to **imposition of penalty of twice the cost of meter.** The same may lead to black listing even, as decided by NTESCL/WBSEDCL. In this connection the decision of NTESCL/WBSEDCL shall be final.

## 10. PACKING & FORWARDING :

The equipment shall be packed in cartons / crates suitable for vertical / horizontal transport as the case may be, and suitable to withstand handling during transport and outdoor storage during transit. The supplier shall be responsible for any damage to the equipment during transit, due to improper and inadequate packing. The easily damageable material shall be carefully packed and marked with the appropriate caution symbol. Wherever necessary, proper arrangement for lifting, such as lifting hooks etc., shall be provided. Supplier without any extra cost shall supply any material found short inside the packing cases immediately.

The packing shall be done as per the standard practice as mentioned in IS 15707: 2006. Each package shall clearly indicate the marking details (for e.g., manufacturer's name, Sl. Nos. of meters in the package, quantity of meter, and other details as per supply order). However, he should ensure the packing is such that, the material should not get damaged during transit by Rail / Road.

## 11. GENERAL :

a) Principle of operation of the meter, outlining the methods and stages of computation of various parameters starting from input voltage and current signals including the sampling rate, if applicable shall be furnished by the bidder.

b) The Components used for manufacture of meter should be of high quality and the bidders should confirm component specification as specified below in Annexure-III.

c) Bidders should compulsorily fill Annexure-I, Annexure-II & Annexure-III for technical qualification.

### Component Specifications:

The meters shall be designed and manufactured using SMT (Surface Mount Technology) components, except for power supply components, LED / LCD etc., which are PTH type.

All the material and electronic power components used in the manufacture of the meter shall be of highest quality and reputed makes so as to ensure higher reliability, longer life and sustained accuracy.

Sl. no.	Component Function / Feature	Requirement	Make / origin
1.	Current Element	E-beam /spot welded shunts shall be provided in the phase element and C.T. in the neutral. Alternatively, both the current elements (phase & neutral) shall have Shunts with proper isolation.	Any make or origin conforming to IS-2705
2.	Measurement / computing chips	The Measurement / computing chips used in the meter should be with the Surface mount type along with the ASICs.	USA: Analog Devices, AMS, Cyrus Logic, Atmel, SAMES, Texas Instruments. Teridian, JAPAN: NEC, Freescale, Renesas. Holland: Phillips,
3.	Memory chips	The memory computing chips should not be affected by the external parameters like sparking, high voltage spikes or electrostatic discharges.	USA: Atmel, National Semiconductors, Texas Instruments, Teridian, ST Japan: Hitachi, Oki. Freescale. Holland /Koria : Philips
4.	Display modules	The display modules should be well protected from the external UV radiations. The display should be clearly visible over an angle of at least a cone of 70°. The construction of the modules should be such that the displayed quantity should not be disturbed with the life of display. The display component should be S TN type industrial grade with extended temperature range.	Singapore : Bonafied Technologies Korea: Advantek Japan : Hitachi, Sony. Haijing, Truly semiconductors,

5.	Communication modules	Communication modules should be compatible for the RS 232 ports	USA: National Semiconductors, HP, ST. Teridian Holland/ Korea: Philips Japan: Ligitek Germany: Siemens Taiwan: Everlight
6.	Optical port	Optical port should be used to transfer the meter data to meter reading instrument. The mechanical construction of the port should be such to facilitate the data transfer easily. <b>Infrared communication port is not acceptable.</b>	USA: National Semiconductors, HP, Holland/Korea: Philips Japan: Hitachi Taiwan: Ligitek, Osram
7.	Power Supply	The power supply should be with the capabilities as per the relevant standards. The power supply unit of the meter should not be affected in case the maximum voltage of the system appears to the terminals due to faults or due to wrong connections.	SMPS type or better as specified.
8.	Electronic components	The active & passive components should be of the surface mount type & are to be handled & soldered by the state of art assembly processes.	USA: National Semiconductors, Atmel, Phillips, Texas Instruments, ST, Onsemi. Japan: Hitachi, Oki, Toshiba. Freescale Korea: Samsung.
9.	Mechanical parts	The internal electrical components should be of electrolytic copper & should be protected from corrosion, rust etc. The other mechanical components should be protected from rust, corrosion etc. by suitable plating / painting methods.	

NEW TOWN ELECTRIC SUPPLY COMPANY LIMITED  
(A FRANCHISEE OF WBSEDCL)  
SPECIFICATION PREPARED BY  
WEST BENGAL STATE ELECTRICITY DISTRIBUTION COMPANY LIMITED

10.	Battery	Lithium / Lithium-ion with guaranteed life of 10 years	Renata, Panasonic, Varta, Tedrium, Sanyo, National, Tadiran, Duracell, Tekcell
11.	RTC / Micro controller	The accuracy of RTC shall be as per relevant IEC / IS standards	USA: Teridian Dallas Atmel, Motorola, Microchip Japan: NEC, Oki, Hitachi, Freescale Holland / Korea: Phillips

## **ANNEXURE - I**

### **GUARANTEED TECHNICAL PARTICULARS OF AC SINGLE PHASE, CL 1.0, 10-60 A, STATIC WHOLE CURRENT ENERGY METER WITH LCD DISPLAY**

<b>Sl. No.</b>	<b>Particular</b>	<b>Min. Requirement as per Specification</b>	<b>As offered</b>
1.	Name of manufacturer		
2.	Type, name & number		
3.	Standard Applicable	IS:13779/1999, IS: 12346 / 1988, IS:14434 / 1998, CEA regulation no. 502/ 70 / CEA / DT&D dt.17.03.06 and CBIP technical report no.88 with its latest amendment as on date..	
4.	Type of Meter (Model No.)		
5.	Rating		
(i)	Accuracy Class	Class-I	
(ii)	Rated Voltage	240V (+ 20%, - 30%)	
(iii)	Rated current	I <sub>b</sub> -10 Amp. I <sub>max</sub> - 60 Amp	
(iv)	Rated frequency	50 Hz ± 5%	
(v)	Power factor	0 lag to Unity to 0 lead	
(vi)	Minimum saturation current	Bidders to specify	
(vii)	Meter Constant (imp / KWH)	-do-	
6. (i)	Maxm. Continuous current rating (Amp.)	60 Amps.	
(ii)	Continuous current rating of terminals for two hours	90 Amps	
(ii)	Running with no load & (-)70% to 120 % voltage	No creeping	
7.	Short time over current for 10 milliseconds	30 times I <sub>max</sub> for one half cycle at rated frequency	
8.	Starting current at which meter shall run & continue to run	0.2% of I <sub>b</sub> at rated voltage and unity power factor	
9.	Power loss at rated frequency & reference temperature		
(a)	Current circuit at rated current	Less than 1 VA	
(b)	Voltage circuit at rated current including CIU	Less than 2.0W / 8VA	
10.	Type of material used		
(a)	Base		

NEW TOWN ELECTRIC SUPPLY COMPANY LIMITED  
(A FRANCHISEE OF WBSEDCL)  
SPECIFICATION PREPARED BY  
WEST BENGAL STATE ELECTRICITY DISTRIBUTION COMPANY LIMITED

<b>Sl. No.</b>	<b>Particular</b>	<b>Min. Requirement as per Specification</b>	<b>As offered</b>
	<i>Material</i>	<i>High Impact strength, non- hygroscopic, fire retardant, fire resistant, UV stabilised poly carbonate (Lexan 503R or equivalent)</i>	
(b)	<i>Meter cover</i>	<i>High Impact strength, non- hygroscopic, fire retardant, fire resistant, UV stabilised Transparent poly carbonate (Lexan 943A or equivalent)</i>	
(c)	<i>Terminal Block</i>		
	<i>Material</i>	<i>Material High Impact strength not hygroscopic, fire retardant, fire resistant, UV stabilised poly carbonate (Lexan 500R or equivalent) Barrier of adequate size shall be provided between phase and neutral</i>	
(d)	<i>Terminal cover</i>		
	<i>Material</i>	<i>High Impact strength, non- hygroscopic, fire retardant, fire resistant, glass reinforced poly carbonate (Transparent)&amp; non detachable with hinging arrangement (Lexan 943A or equivalent).</i>	
(f)	<i>Screw</i>		
	<i>(i) Material</i>	<i>Tin / Nickel Plated - Brass</i>	
	<i>(ii) Size</i>	<i>Bidders to specify</i>	
11.	<i>Internal diameter of Terminal Hole</i>	<i>Min. 5.5 mm</i>	
12.	<i>Centre to Centre clearances between adjacent terminals</i>	<i>13 mm</i>	
13	<i>Transducers</i>		
(i)	<i>Input</i>	<i>E-beam / spot welded Shunts shall be provided in the phase element and C.T /Shunt/ HALL EFFECT SENSOR in the neutral. Voltage: Potential divider (PT less)</i>	
(ii)	<i>Output</i>	<i>LCD</i>	
(iii)	<i>Shunt resistivity</i>	<i>Bidders to specify</i>	
(iv)	<i>C.T. – no of turns</i>	<i>-do-</i>	

NEW TOWN ELECTRIC SUPPLY COMPANY LIMITED  
(A FRANCHISEE OF WBSEDCL)  
SPECIFICATION PREPARED BY  
WEST BENGAL STATE ELECTRICITY DISTRIBUTION COMPANY LIMITED

Sl. No.	Particular	Min. Requirement as per Specification	As offered
14.	Type of Register	LCD suitable for operation up to 80°C	
(i)	No. of Digits	6 (integer only)/ 7 is preferable	
(ii)	Size of Numerals	8.0 X 5 mm (minimum)	
15.	Display		
(i)	On Scroll Mode & Auto display mode	Both required	
(ii)	Type of push button	Spring loaded push button to be provided on top cover of meter to read parameters. Any other good quality push button may be accepted if found suitable after through checking / inspection.	
16.	Reading on power off condition	Meter shall be able to display reading during power outage through the push button provided on the meter with facility for hands free meter reading with auto-off provisions.	
17.	a) Battery of Real time clock	(i) It shall be Lithium / Lithium-ion battery having at least 10 years of life	
		(ii) The drift in time shall not exceed +/- 3 minutes per year	
	b) Battery for Display during power off condition	It shall be Lithium / Lithium-ion battery having at least 10 years of life	
18.	Fixing/sealing arrangement		
(i)	Fixing of meter	3 fixing holes (one at top & two at bottom under terminal block). The top fixing screw shall not be accessible after meter is fixed to meter box base.	
(ii)	Sealing of meter cover to Base	At least, two sealing provision/screws shall be provided for proper fixing of the meter cover so that access to the working part shall not be possible without breaking the seal. Necessary provision shall be kept for fixing the utility seal also.	
		The meter cover shall be permanently fixed to the base by ultrasonic welding or any other technology which is equally or more efficacious so that cover cannot be opened without breaking, i.e. the meter should be break to open type. <b>Meter should have an indication in its display if top cover is removed and any puncture/hole in bottom side.</b>	
19.	Type of hinged un-detachable terminal cover	Terminal cover shall be hinged.	



<b>Sl. No.</b>	<b>Particular</b>	<b>Min. Requirement as per Specification</b>	<b>As offered</b>
20.	<i>Performance of meter in tamper conditions</i>		
	<i>(i) Phase-neutral interchanged</i>	<i>Should work within specified accuracy</i>	
	<i>(ii) Main &amp; load wire are interchanged</i>	<i>----do----</i>	
	<i>(iii) Load is not terminated back to meter &amp; current is drawn through local earth fully or partially</i>	<i>---do---</i>	
	<i>(iv) Neutral disconnected from both incoming &amp; outgoing and load drawn through local earth</i>	<i>-do- provided threshold current is 1 Amp. &amp; above</i>	
20	<i>(v) Indication of above tamper condition</i>	<i>LCD / LED indication.</i>	
21.	<i>Suitability of meter to sustain over voltage i.e. phase to phase voltage injected between phased &amp; neutral</i>	<i>Should sustain</i>	
22	<i>Electromagnetic compatibility (EMI / EMC severity level)</i>	<i>As per IS 13779: 1999</i>	
23.	<i>(i) Effect on accuracy of external electromagnetic interference of electrical discharge, external magnetic field &amp; DC current in AC supply or in neutral</i>	<i>Should work within accuracy as per latest ISS &amp; CBIP report -88,304 with latest amendment.</i>	
	<i>(ii) Immune to Electrostatic discharge upto 35kV</i>	<i>Exceeding 35kV it should log as tamper</i>	
	<i>(iii) Current reversal, Neutral disturbance &amp; Magnetic tamper logging in memory</i>	<i>Meter shall log last 100 events with date and time</i>	
24.	<i>Effect on accuracy under tamper conditions / influence conditions</i>	<i>Should work within accuracy specified in IS: 13779 / 1999, and CBIP tech. Report 88. Error beyond +/- 4 % will not be acceptable for conditions not specified in IS: 13779 / 1999 &amp; CBIP tech. Report 88.</i>	
25.	<i>Drift in accuracy of measurement with time</i>	<i>No Drift in accuracy in measurement with time</i>	

<b>Sl. No.</b>	<b>Particular</b>	<b>Min. Requirement as per Specification</b>	<b>As offered</b>
26.	<i>Name plate details</i>	<i>It should cover all the details as prescribed in Clause-21</i>	
27.	<i>Approximate weight of meter</i>	<i>To be indicated</i>	
28.	<i>Type of mounting</i>	<i>Projection type</i>	
29.	<i>Calibration</i>	<i>Meter shall be software calibrated at factory &amp; there shall not be any mechanical form of calibration, such as, mechanical preset / trim port / potentiometer etc. so that any adjustment in calibration is not possible after freezing the meter constant.</i>	
30.	<i>Manufacturing activity</i>		
	<i>(i) Mounting of components on PCB shall be SMT type</i>	<i>SMT type and ASIC technology</i>	
	<i>(ii) Compliance to assurance</i>	<i>To be complied</i>	
31.	<i>Testing facility</i>		
(i)	<i>Fully automatic computerised meter test bench with print out facility shall be available</i>	<i>Must be available</i>	
(ii)	<i>Make and Sl. No. of Test bench</i>	<i>To be indicated</i>	
(iii)	<i>Accuracy of ESS duly calibrated</i>	<i>---do---</i>	
(v)	<i>Following in house testing facility shall be available :</i>		
	<i>(i) AC high voltage test</i>	<i>Must be available</i>	
	<i>(ii) Insulation test</i>	<i>--do--</i>	
	<i>(iii) Test of no load condition</i>	<i>--do--</i>	
	<i>(iv) Test of Starting condition</i>	<i>--do--</i>	
	<i>(v) Test on Limits of error</i>	<i>--do--</i>	
	<i>(vi) Power loss in voltage and current circuit</i>	<i>--do--</i>	
	<i>(vii) Test of Repeatability of</i>	<i>--do--</i>	
	<i>(viii) Test of meter constant</i>	<i>--do--</i>	
	<i>(xi) Power loss in voltage &amp; current circuit</i>	<i>--do--</i>	
	<i>(x) Test of Magnetic influence</i>	<i>--do--</i>	

<b>Sl. No.</b>	<b>Particular</b>	<b>Min. Requirement as per Specification</b>	<b>As offered</b>
32.	<i>Whether offered meter type tested as per ISS 13779 / 1999 Table-20 for all the following tests (indicate name of laboratory /Reference of report No. &amp; date)</i>	<i>Clause No – 3 of general requirement.</i>	<i>Name of Lab Type Test Report Ref. No.</i>
(i)	<i>Vibration test</i>	<i>12.3.2</i>	
(ii)	<i>Shock test</i>	<i>12.3.1</i>	
(iii)	<i>Spring Hammer test</i>	<i>12.3.3</i>	
(iv)	<i>Protection against penetration of dust and water</i>	<i>12.5</i>	
(v)	<i>Test of resistance to heat &amp; fire</i>	<i>12.4</i>	
(vi)	<i>Power consumption</i>	<i>12.7.1</i>	
(vii)	<i>Influence of supply voltage</i>	<i>12.7.2</i>	
(viii)	<i>Voltage dips and interruptions</i>	<i>12.7.2.1.</i>	
(ix)	<i>Short time over current</i>	<i>12.7.3</i>	
(x)	<i>Influence of self heating</i>	<i>12.7.4</i>	
(xi)	<i>Influence of heating</i>	<i>12.7.5</i>	
(xii)	<i>Impulse voltage test</i>	<i>12.7.6.2</i>	
(xiii)	<i>AC high voltage test</i>	<i>12.7.6.3</i>	
(xiv)	<i>Insulation test</i>	<i>12.7.6.4.</i>	
(xv)	<i>Radio Interference measurements</i>	<i>12.9.5</i>	
(xvi)	<i>Fast transient burst test</i>	<i>12.9.4</i>	
(xvii)	<i>Electrostatic discharge</i>	<i>12.9.2</i>	
(xviii)	<i>Immunity to electro-magnetic H.F. field</i>	<i>12.9.3.</i>	
(xix)	<i>Test for meter constant</i>	<i>12.15</i>	
(xx)	<i>Test of starting conditions</i>	<i>12.14</i>	
(xxi)	<i>Test of no load condition</i>	<i>12.13</i>	
(xxii)	<i>Ambient temp. influence</i>	<i>12.12</i>	
(xxiii)	<i>Test of influence quantities</i>	<i>12.11</i>	
(xxiv)	<i>Interpretation of test results</i>	<i>12.16</i>	
(xxv)	<i>Repeatability error test</i>	<i>12.17</i>	
(xxvi)	<i>Dry heat test</i>	<i>12.6.1</i>	
(xxvii)	<i>Cold test</i>	<i>12.6.2</i>	
(xxviii)	<i>Damp heat cycle test</i>	<i>12.6.3</i>	
(xxix)	<i>Test of influence of immunity to Earth fault</i>	<i>12.8</i>	
(xxx)	<i>Limits of error</i>	<i>11.1</i>	

<b>Sl. No.</b>	<b>Particular</b>	<b>Min. Requirement as per Specification</b>	<b>As offered</b>
33.	Guarantee period of meter	5-1/2 years from the date of supply. Guarantee period shall be printed on the nameplate.	
34.	BIS licence		
34.1	BIS licence No. & dt. with its validity for ISI certification mark on offered meter.	To be mentioned	
34.2	Details of meter design for which above BIS certification has been obtained: -	To be mentioned	
(i)	Ratio of $I_b$ to $I_{max}$		
(ii)	Material of meter body		
(iii)	Type of energy registering counter		
(iv)	Type of technology (Digital/Analog)		
(v)	Grade of printed circuit Board material		
(vi)	Type of assembly of component used (SMT)		
(vii)	Meter constant (IMP / KWh)		
(viii)	Auxiliary power circuit (with PT or PT less)		
(ix)	Current circuit (CT / Shunt combination or only shunt)		
(x)	Accuracy class		
35.	ISO accreditation no. & dt. with its validity		
36.	Other parameters / features not covered in the above GTP	Conform to specification of IS-13779 / 1999 & CBIP technical report No.88 (with its latest amendment).	
37	Past Experience	Copies of order executed in last two years along with GTP of the supplied meters to be enclosed	

## Annexure - II

### Pre-Qualification Conditions for Single Phase Static Meters

Sl. No.	Particulars	Remarks
1	Bidders must have valid BIS certification for the offered meter other wise the meter will not be considered for acceptance.	Yes / No
2	Bidder preferably posses ISO 9001 certification	Yes / No
3	Bidder should be manufacturers of static meters having supplied Static 1-ph or 3-phase meters with memory and LCD display to Electricity Boards / Utilities in the past 2 years. Bidder having past experience less than 2 years i.r.o. manufacturing & supply of meters will be considered for acceptance of sample meter. If the bid is techno-commercially acceptable on the basis of sample meter testing and evaluation of bid, promotional order may be placed with the bidder as per our present purchase policy.	Yes / No
4	Bidder has Type Test certificate for the Type of offered meter not more than 3 (three) years old	Yes / No
5	Bidders should have dust free, static protected environment for manufacture, assembly and Testing.	Yes / No
6	Bidder should have automatic computerized test bench for lot testing of meters.	Yes / No
7	Bidder has facilities of Oven for ageing test.	Yes / No
8	Bidder shall submit certificate for immunity against magnetic influence of 0.2 T AC. & 0.5 T DC. from a NABL accredited Laboratory, for the same type of meter as offered.	Yes / No

### Annexure - III

Sl. No.	Component Function / Feature	As per Requirement	Make / origin
1	Current Element		
2	Measurement / Computing chips		
3	Memory chips		
4	Display modules		
5	Communication modules		
6	Optical port		
7	Power Supply		
8	Electronic components		
9	Mechanical parts		
10	Battery		
11	RTC / Micro controller		

**ANNEXURE - IV**

<b>Sl. No.</b>	<b>LIST OF DOCUMENTS TO BE SUBMITTED DURING SAMPLE SUBMISSION</b>			
1	<i>Attested copy of type test reports from NABL accredited laboratory</i>			
2	<i>Attested copy of BIS certificates of the same type of meter submitted as sample</i>			
3	<i>Attested certificates as regards material used for meter case, cover &amp; terminal block.</i>			
4	<i>Annexure – II as per tender documents</i>			
5	<i>Annexure – III as per tender documents</i>			
6	<i>Operating manual of the meter submitted</i>			

WBSEDCL

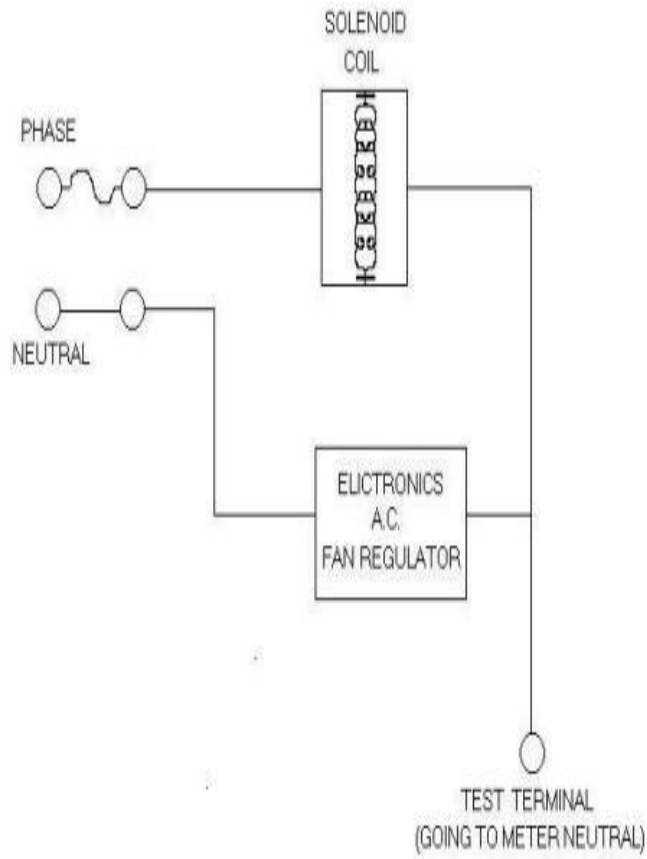

CIRCUIT DIAGRAM FOR TEST JIG TO INTRODUCE CHOPPED A.C. IN NEUTRAL



WBSEDCL

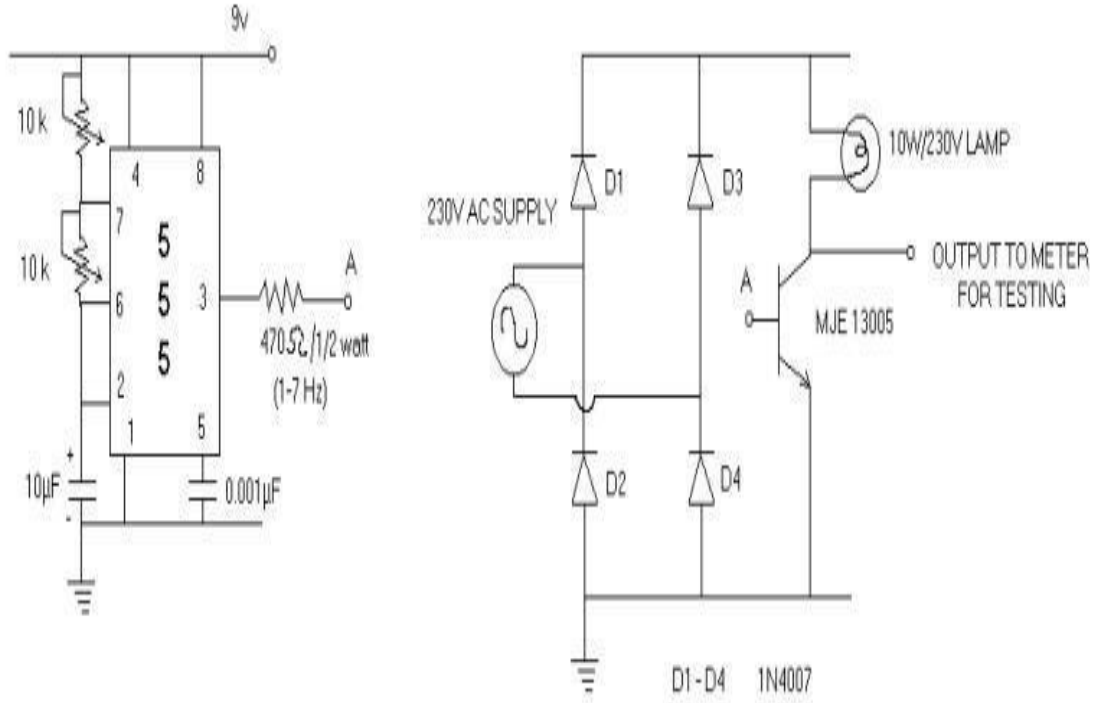

CIRCUIT DIAGRAM FOR TEST FIGURE TO INTRODUCE PULSATING D.C. IN NUTRAL

### Drawing No. 1

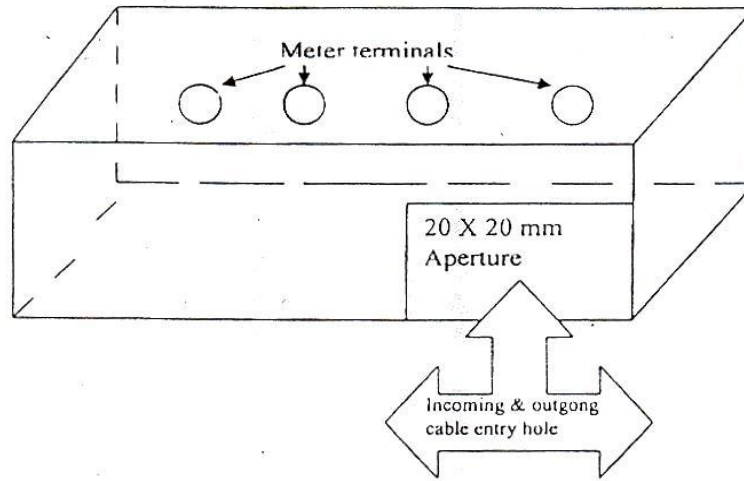

Terminal cover of Single phase Fully Static meter